



SPRING ONION CLEANING LINE



Operating principle:

The machine is designed for cleaning spring onions. The following types are available: S and L. The type S cuts the roots 1 time with high speed knife and leaves 1 time with a flat knife. Inclusive washing. The cutting length is adjustable. After washing and cutting the onions are coming on the grading belt for final processing. At the L type the 1st root cutting with high speed knife is done, afterwards peeled and washed and a 2nd root cutting with high speed knife and leaf cutting with a double smooth knives. The cutting length is adjustable at both machines. After washing, peeling and cutting the onions are coming into the sorting area where the final control takes place. At the L machine, operators can place the onions as bundles at the upper belt. The bundles are tied at two points by binding machines. Finally, the onion bundles are again cut off at the root and leaf side and washed again. The result is a clean and cut off bundle. The spring onions can be placed on the filling part with one or two people. You can sort with 3 or more persons.

Film: <https://www.christiaensagro.com/en/products/spring-onions#product-video-17>

Advantages:

- Labour savings
- Cleaner bundle (washing before bundling)
- Variable settings

Options:

S and L machine: Waste discharge systems, , Revolving sorting table, Extension filling- grading part, Automatic binding, Logistics. Only L machine: Water recycling

Technical Data	S-type	L-type
Length	+/-4.200 mm	+/-6.300 mm. (dep. on the model)
Width frame	+/-1.200 mm.	+/-1.200 mm.
Height	+/-1.600 mm.	+/-1.600 mm.
Filling and sorting height	+/-1.000 mm, adjustable	+/-1.000 mm, adjustable
Length filling part	+/-1.000 mm. (dep. on the model)	+/-1.000 mm. (dep. on the model)
Length grading part	+/-3.000 mm. (dep. on the model)	+/-3.000 mm. (dep. on the model)
Cutting length	240 - 480 mm.	240 - 480 mm
Water usage	+/- 3.000Ltr/hour	+/- 24.000Ltr/hour.
Drive	Hydraulic	Hydraulic
Power Supply	16A 400V 50Hz 3f+N+pe	16A 400V 50Hz 3f+N+pe
Oil	biodegradable	biodegradable
Speed	max. 13,5 mtr/min adjustable	max. 13,5 mtr/min adjustable
Frame	Stainless steel -304	Stainless steel -304
Binding machine	No Binding	max. 3000 pc/hour



Type S

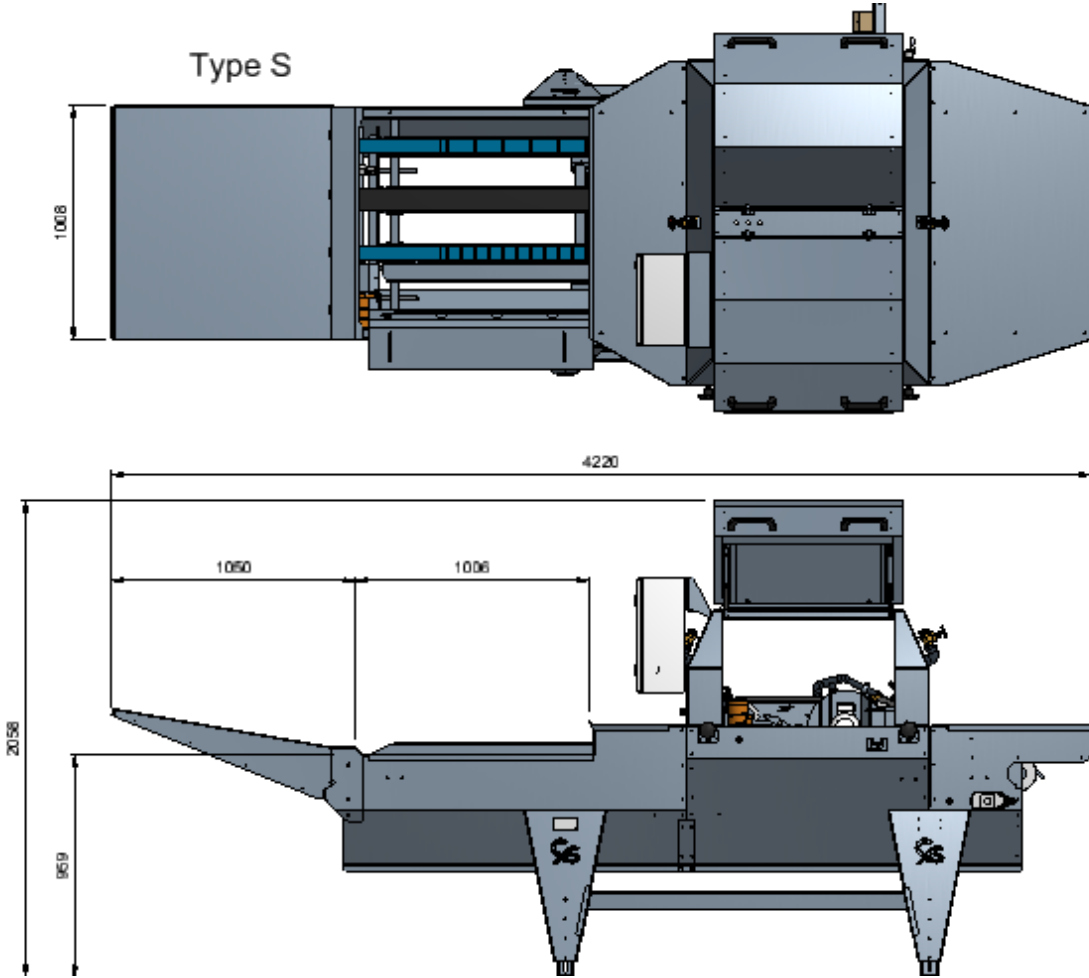

L-type

